



**S-500 / S-500L**  
**Snow Machine**  
**User Manual**  
**- English**  
**- 中文**





1. Introduction .....	1
2. Safety Information.....	1
3. Package Contents & Inspection.....	2
4. Machine Details.....	3
5. Technical Label Information.....	3
6. Snow Fluid.....	3
7. Setting and Manual Operation.....	3
8. Adjustable Mounting Bracket.....	4
9. Control Settings .....	5
10. DMX Connection .....	6
11. W-DMX Signal Status .....	6
12. SC-3 Cable Remote (Optional).....	7
13. WTR-20 Wireless Remote (Optional) .....	7
14. TIMO-WTR-70 2in1 Wireless Module (Optional).....	8
15. TIMO-W-DMX-PCBR W-DMX Receiver (Optional) .....	8
16. ST-10 Air Hose Extension (Optional).....	9
17. Service and Maintenance.....	9
18. Technical Specifications .....	10
19. Warranty Disclaimer.....	10
20. Machine Dimension.....	11
1. 前言 .....	12
2. 安全注意事項 .....	12
3. 包裝內容與檢查 .....	13
4. 機器訊息 .....	14
5. 技術標籤資訊 .....	14
6. 雪花水 .....	14
7. 設定與手動操作說明 .....	15
8. 可調式安裝支架 .....	15
9. 控制設定 .....	16
10. DMX 說明.....	17
11. 無線 DMX 訊號說明.....	17
12. SC-3 有線控制器(選配) .....	18
13. WTR-20 無線控制器(選配) .....	18
14. TIMO-WTR-70 二合一無線模組(選配).....	19
15. TIMO-W-DMX-PCBR 無線 DMX 接收器(選配).....	20
16. ST-10 延長管(選配).....	20
17. 維護和保養 .....	20
18. 技術規格 .....	21
19. 保固聲明 .....	21
20. 機器尺寸圖 .....	22
Appendix I – Grounding Instruction.....	23

# SILENT SNOW MACHINE **S-500** *User Manual*

## 1. Introduction

Please read all the user manual before operating the machine, and place the manual where the user can refer to it at all time. The manual includes how to install and operate the machine under safe condition and explain all the labels printed on the machine. If you encounter any problem, contact your local Antari dealer for assistant immediately.

## 2. Safety Information

	<b>DANGER</b>	If the danger is not avoided, it will cause death or serious injury
	<b>WARNING</b>	If the warning is not heeded, it can cause death or serious injury.
	<b>CAUTION</b>	If the precaution is not taken, it may cause minor or moderate injury.



### **DANGER**

- Must connect the machine to the correct rated voltage or it might lead to an electrical shock or a burn and may cause serious consequences.
- Must connect the machine to a protected circuit and ensure it is properly grounded to avoid the risk of electrocution. For grounding instruction, please refer to Appendix I on page 23.
- Do not operate the machine with a bundled power cord, it could lead to a fire hazard.
- When operating the machine, do not point at people, animals, or fire.



### **WARNING**

- Please operate the machine on a flat, level hard and well ventilated surface area, reserve at least 50cm space around the machine and make sure there is no flammable gas or material nearby.
- Do not disassemble, repair or modify the machine, it may cause damages, malfunction, risk of electrical shock or result in fire.
- The machine can only be operated by adults or professionals, is not intended for use by person with reduced physical sensory, mental capabilities, or lack of experience and knowledge including children.
- Do not leave the machine running unattended, make sure all powers are off when leaving.
- Children should be supervised to ensure that they do not play with the machine.
- Do not use the machine upside down or tilt it, it might cause damages or malfunction.
- Please store the fluid inside in a well ventilated area without direct sunlight and keep out of reach of children. In case of eye contact or accidentally swallow the fluid, please seek medical attention immediately.



### **CAUTION**

- Keep the machine dry at all time. The machine is not waterproof, do not expose the machine to water, rain, or moisture environment.
- Please make sure the power outlet is not damaged or loose before plug in the power cord.
- If the power cord is damaged, it must be replaced by Antari or its local dealers, otherwise the warranty will be void.
- Before operating the machine, please sure the fluid is filled in the fluid tank to avoid the pump in idling state which could lead to overheat or malfunction.
- Before transporting the machine, please make sure the fluid is drained and tank is empty. (Recommend using original package)
- The machine is for indoor use only.
- Do not operate the machine in any area with unstable voltage.
- If you experience strange sound or malfunction, turn off the power and unplug the power cord immediately and contact your local Antari dealer for assistant.

- Do not contact any moving part.
- Only use accessories recommended or sold by Antari.
- Please make sure the power is off when not using the machine and unplug the power cord if not intend to use for a long period of time.
- To disconnect, turn all controls to the off position, then remove plug from outlet.
- Do not unplug by pulling on cord. To unplug, grasp the plug, not the cord.
- Unplug from outlet before servicing or cleaning.
- Do not operate the machine with a damaged cord or plug, or after the machine malfunctions or is dropped or damaged in any manner. Return machine to the nearest authorized service facility for examination, repair, or electrical or mechanical adjustment.
- To ensure the lifespan of the machine, please only use snow fluid manufactured by Antari, using other snow fluid or additive might cause machine malfunction.

Before operating the machine, please read all warning labels on the machine, description as below:

Front Cover Printing

**WARNING!**

PLEASE USE ANTARI FLUID ONLY.

NEVER ADD FLAMMABLE SUBSTANCE.

### 3. Package Contents & Inspection

Immediately upon receiving the machine, carefully unpack the carton, check the content to ensure it is the correct model and all parts are included. If any part appears to be damaged or missing during transportation, please contact your local dealer and return in original package for inspection.

#### 3.1 Package Contents

S-500	S-500L
1 x S500 Snow Machine	1 x S500L Snow Machine
1 x 20 Liters Fluid Tank	1 x 20 Liters Fluid Tank
1 x Fluid Tube 15cm	1 x Fluid Tube 15cm
1 x Neutrik powerCON Power Cable	1 x Neutrik powerCON Power Cable
1 x Air Hose 10m	1 x Air Hose 20m
1 x Nozzle	1 x Nozzle
1 x User Manual or Scan QR Code on the Machine	1 x User Manual or Scan QR Code on the Machine

#### 3.2 Optional Accessories

Item Code	Description
SC-3	Cable Remote
WTR-20	Wireless Remote (W-2 Transmitter/W-2 Receiver)
TIMO-WTR-70	2in1 Wireless Module (Wireless+W-DMX)
TIMO-W-DMX-PCBR	W-DMX Receiver
ST-10	10 Meter Extension Hose
PM-1	Pan Motor

## 4. Machine Details

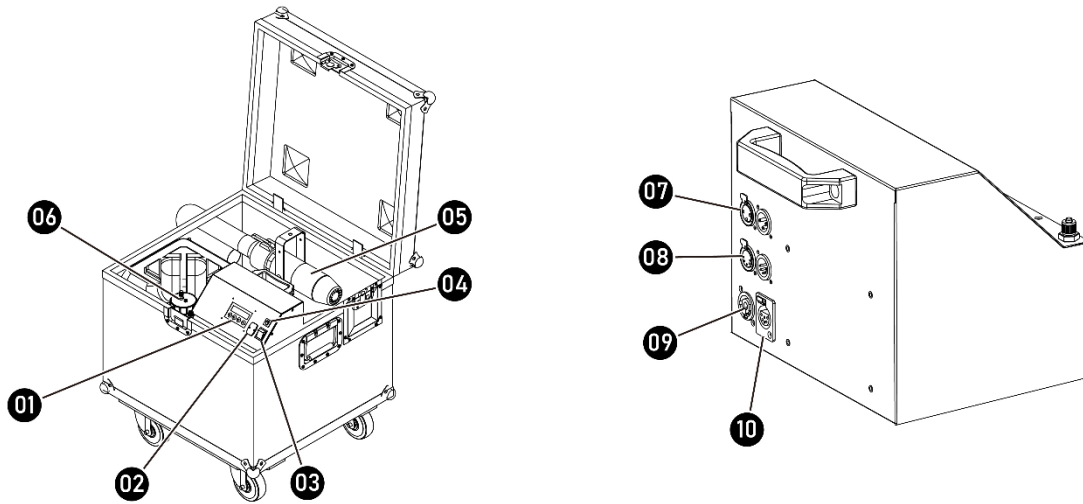

01. Digital Control Interface	06. 20 Liter Fluid Tank
02. Expansion Socket	07. XLR 3-Pin Connector (DMX)
03. Power Switch	08. XLR 5-Pin Connector (DMX)
04. Breaker	09. Neutrik powerCON Connector (Power)
05. Nozzle	10. XLR 4-Pin Remote Connector (Remote)

## 5. Technical Label Information

Please read the technical label information on the back of the machine before operating it.

1. Model Name	5. Breaker/Fuse
2. Input Voltage	6. QR CODE for User Manual
3. Frequency	7. Serial No.
4. Rated Power	

## 6. Snow Fluid

 <b>CAUTION</b>	<p>Always turn off the power before filling the fluid tank. Do not add flammable liquid to the fluid tank. If fluid gets inside the machine, please contact your local Antari dealer for assistant.</p>
--------------------	---

- Only the snow fluid manufactured by Antari can be used, do not mix or dilute the snow fluid.
- The machine is tested and calibrated with the specific snow fluid to get the best performance.
- Please empty the fluid in the tank before switching to another fluid to avoid mixing.
- The warranty on your snow machine will be void if you use snow fluid not manufactured by Antari.

## 7. Setting and Manual Operation

 <b>WARNING</b>	<p>Machine falling off might cause serious injury, please make sure it is secure and firm on the overhead.</p>
--------------------	--

- Step 1.** Place the machine on a flat, level hard and well ventilated surface area and reserve at least 50cm open space around the machine, and make sure there is no flammable gas or material nearby;
- Step 2.** Fill the fluid tank with Antari approved snow fluid;
- Step 3.** Plug the machine to the power outlet. Please read the technical label on the back of the machine and make sure the power outlet has the correct rated voltage for the machine;
- Step 4.** Turn on the machine, once the machine is ready for operation, the LCD display will show “Antari S-500 Ready To Snow”;
- Step 5.** To start snowing, press [TIMER] once and to stop snowing, press [STOP], this will run based on “interval” & “duration” setting in the main menu;
- Step 6.** To start snowing, you can also press [VOLUME] button once and to stop snowing, press [STOP];
- Step 7.** To turn off the machine, please make sure the machine is not operating then turn of the power. If you will not use the machine a long period of time, please remove the power cord.

## 8. Adjustable Mounting Bracket

Illustration below demonstrates how to adjust the mounting bracket, use screws for surface mounting or clamps for truss mounting.

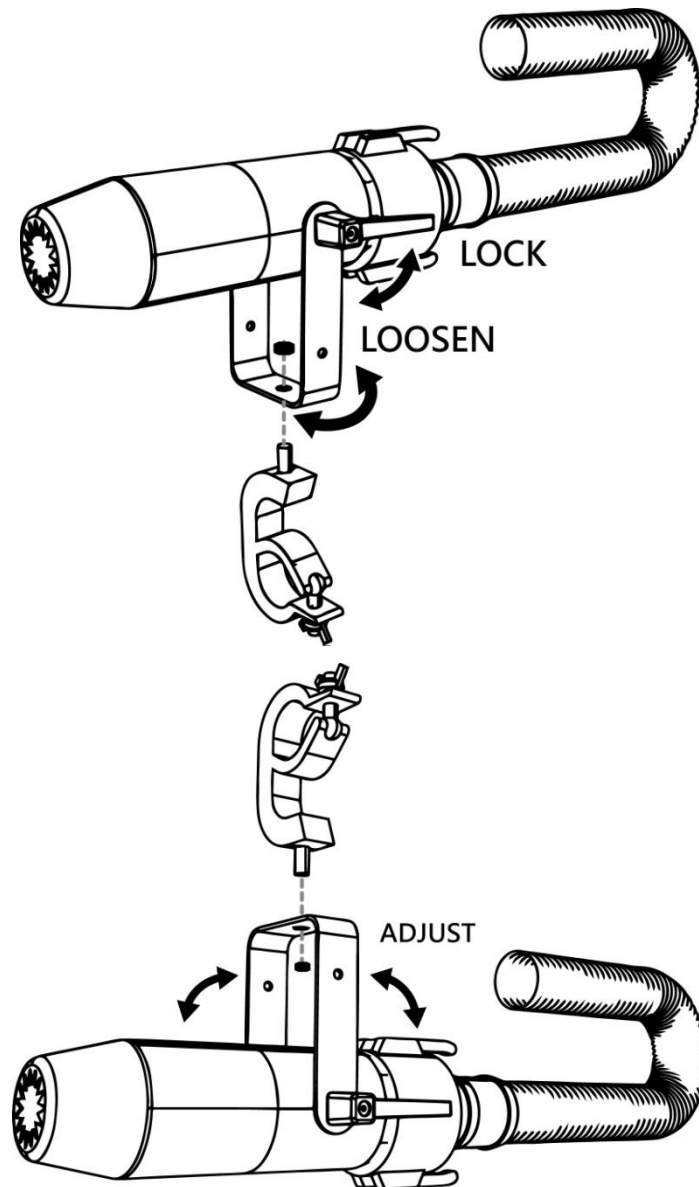

### Installation Precaution:

- Use supplied mounting bracket or rigging clamp to install nozzle.
- Make sure the installation location, fastening connecting, and rigging hardware can hold at least 10 times of the weight of the nozzle.
- Make sure no combustible or flammable materials are nearby.

- Secure the nozzle with an approved safety cable that can hold at least 10 times of the weight of nozzle.
- Make sure nozzle is installed in a well ventilated area.
- Consider nozzle position and routine maintenance access when selecting an installation location.

## 9. Control Settings

S-500/S-500L Snow Machine can be operated in the following modes. The machine can only accept 1 type of signal at a time.

- Manual
- Timer
- DMX512
- W-DMX
- Wireless
- Cable Remote

### 9.1 Control Panel Description

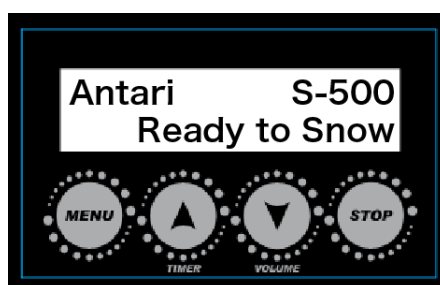

S-500/S-500L Snow Machine can be operated with the onboard digital control interface.

Button	Operating Method	Function
	Press	To enter and scroll through setting menu
	Press	Increase value/Up
	Press	Decrease value/Down
	Press	Press to active timer function
	Press	Press to active volume function
	Press	Return/Stop/Deactive Timer & Volume Function

#### Language Option

To switch the language of the digital control interface, press and hold the [Menu] button then power up the machine and wait until the LCD screen flashes twice. After the two flashes, press [Menu] to choose the language: English and 中文(Chinese). After choosing the desired language, press [STOP] to memorize the setting.

### 9.2 Menu Options Description



Options	Description
Timer Interval xxx Sec	Set Interval Time from 15 - 360 sec
Time Duration xxx Sec	Set Duration Time from 5 - 120 sec
Timer Output xxx%	Set Output Volume from 1 - 100%
Volume Output xxx%	Set Output Volume from 1 - 100%
Fan Speed xxx%	Set Fan Speed from 20 – 100%

Options	Description
DMX512 Add.xxx	Set DMX/W-DMX Address from 001-511
W-DMX Power	Turn ON / OFF W-DMX Function
W-DMX Reset	Unlink from a W-DMX Transmitter
Wireless	Turn ON / OFF Wireless Function
Wireless Register Up: Pair Down: Del	Pair/Unpair Wireless Remote *This menu will not be shown when Wireless is turned off
Run Last Setting	Turn ON / OFF Memory Mode (Turn ON, the machine will remember last setting)

## 10. DMX Connection

### 10.1 DMX Connector Pin Assignment

The machine has a XLR 3-Pin and 5-Pin for DMX connection. The diagram below indicates pin assignment information.

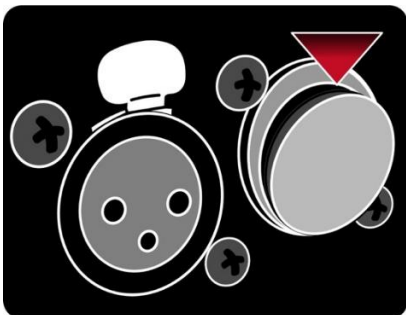
 <p>3 Pin XLR</p>	 <p>5 Pin XLR</p>	<p>The cap on the DMX IN port is a protection cover. Please remove it with your finger before operation.</p> 											
<table border="1"> <thead> <tr> <th>Pin</th> <th>Function</th> </tr> </thead> <tbody> <tr> <td>1</td> <td>Ground</td> </tr> <tr> <td>2</td> <td>Data-</td> </tr> <tr> <td>3</td> <td>Data+</td> </tr> <tr> <td>4</td> <td>N/A</td> </tr> <tr> <td>5</td> <td>N/A</td> </tr> </tbody> </table>			Pin	Function	1	Ground	2	Data-	3	Data+	4	N/A	5
Pin	Function												
1	Ground												
2	Data-												
3	Data+												
4	N/A												
5	N/A												

### 10.2 DMX Setting

Channel 1	DMX Value Range	Function
Snow Output Level	0 – 5	Snow off
	6 – 255	Snow Output 1 – 100%
Channel 2	DMX Value Range	Function
Fan Output Level	0 – 5	Fan 20%
	6 – 255	Fan 21 – 100%

## 11. W-DMX Signal Status

W-DMX Control supports both CRMX and W-DMX protocols

### 11.1 Status of W-DMX

Signal on LCD Display	Wireless DMX Status
○	Transmitter not assigned
◎	Transmitter assigned, no DMX signal
◐	Transmitter link lost or linking to transmitter
●	Transmitter assigned, DMX signal received



## 12. SC-3 Cable Remote (Optional)



SC-3 Cable Remote is an optional accessory for S-500/S-500L Snow Machine, please see instruction below;

Button/Knob	Function
VOLUME [KNOB]	Adjust Volume Output
FAN [KNOB]	Adjust Fan Output
POWER [RED BUTTON]	Power On / Off (Can adjust both Volume/Fan Output)
MAX FAN [GREEN BUTTON]	Fan Max Output Locked, Can Only Adjust Volume Output
PRIMING [YELLOW BUTTON]	Both Volume/Fan Output at Max. Can't Adjust

Note:

- \*\* You must push the red button turn on the power of the remote in order to use it.
- \*\* PRIMING [YELLOW BUTTON] is meant for priming use, when using the machine for the first time or switch a new fluid tank or refill the fluid may not pump properly due to airlock in the tube, you can use this to activate pump at maximum output and push all air out of tube.
- \*\* If you encounter any problem, please contact your local Antari dealer for assistant.

## 13. WTR-20 Wireless Remote (Optional)

WTR-20 Wireless Remote is an optional accessory for S-500/S-500L Snow Machine, it included a W-2 wireless transmitter and a W-2 wireless receiver. If you already purchased the wireless model, it's ready to use. If you purchase the WTR-20 Wireless Remote afterwards, please follow the instruction below. If you encounter any problem, please contact your local Antari dealer for assistant.

### 13.1 W-2 Wireless Transmitter & Receiver

- Battery : 27A 12V
- Effective Range : The effective range is approximately 50m, depends on actual condition, it may vary.
- If effective range is significantly shorter, please change battery.
- W-2 wireless transmitter has 4 buttons, each function as follow:

Button	Function
[A]	Start Snowing
[B]	Stop Snowing
[C]	Increase Snow Output
[D]	Decrease Snow Output



W-2 Wireless Transmitter

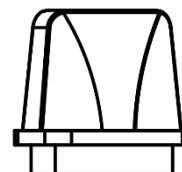

W-2 Wireless Receiver

## 13.2 W-2 Wireless Receiver Installation

If you purchased the WTR-20 Wireless Remote afterwards, please follow the instructions below to install the receiver. If you encounter any problem, please contact your local Antari dealer for assistant.

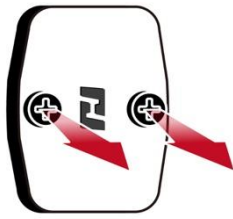

Graph 1

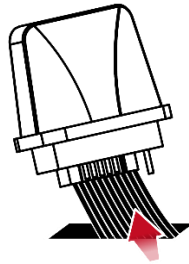

Graph 2



Graph 3

1. Please see graph 1, remove the cover from the pointed place;
2. You will see a white cable like graph 2, pull it out and connect to the W-2 wireless receiver;
3. Screw it back to the machine like graph 3 and follow the instruction on 13.3 for pairing.

## 13.3 Pair & Unpair

Each receiver can pair up to 5 transmitters, please follow the steps below to pair or unpair;

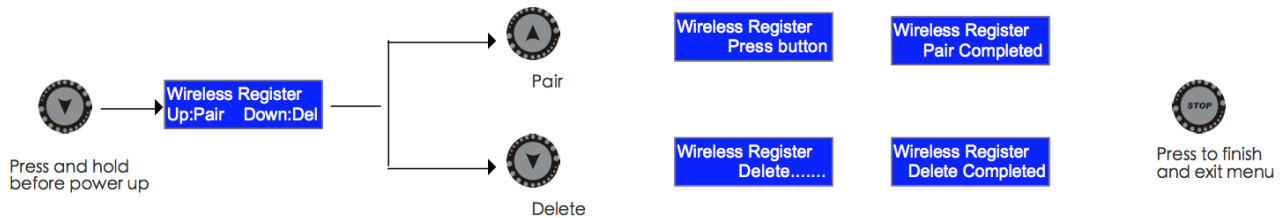

## 14. TIMO-WTR-70 2in1 Wireless Module (Optional)

TIMO-WTR-70 is a 2in1 Wireless Module (Wireless+W-DMX), it is an optional accessory for S-500/S-500L Snow Machine. If you already purchased the machine with this option, it's ready to use. If you purchase afterward, please see the installation manual for details. If you encounter any problem, please contact your local Antari dealer for assistant.

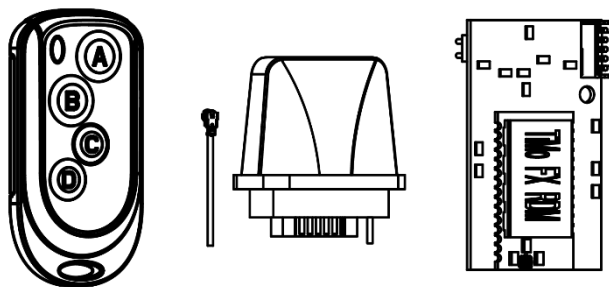

## 15. TIMO-W-DMX-PCBR W-DMX Receiver (Optional)

TIMO-W-DMX-PCBR is a W-DMX receiver, it's an optional accessory for S-500/S-500L Snow Machine. If you already purchased the machine with this option, it's ready to use. If you purchase afterward, please see the installation manual for details. If you encounter any problem, please contact your local Antari dealer for assistant.

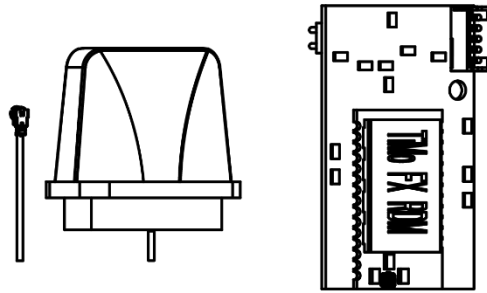

## 16. ST-10 Air Hose Extension (Optional)

The maximum air hose length is 20 meters, illustration below demonstrates how to connect air hose extension.

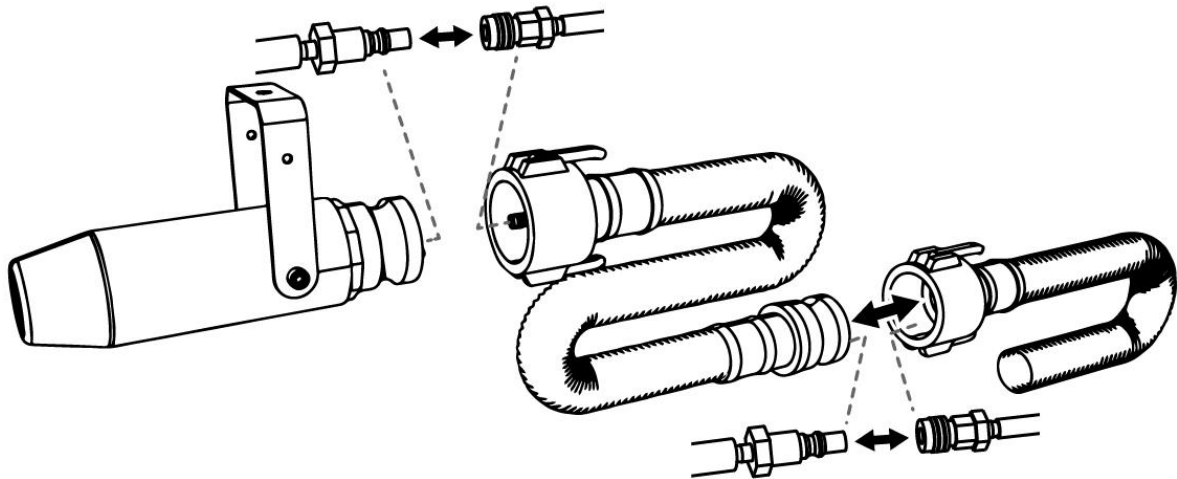

## 17. Service and Maintenance



**DANGER**

Disconnect the power cord before starting maintenance operation!

- Always keep the machine clean and dry.
- Can use an air compressor, a vacuum or a soft brush to remove the dust on the machine.
- Can use a slightly damp cloth to clean the casing.
- Before store or after each use of the machine, pump pure water through the system for at least 1-2 minutes, this will help clean the snow fluid residue and extend the lifespan on the pump and the machine.
- It is recommended to run the machine at least once a month in order to maintain its best performance and output condition.
- Excessive dust and build up liquid residue will reduce the performance and cause overheat.

## 17.1 Breaker Reset

Please follow the instructions below to reset the breaker;

**Step 1.** Disconnect AC power

**Step 2.** Flip break to reset

**Step 3.** Turn on machine for testing

\*\*If the breaker still jumps off after reset, please contact your local Antari dealer for assistance.

### Breaker Specification

120V = 10A 250V

240V = 5A 250V

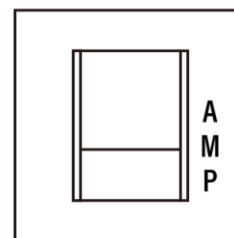

## 18. Technical Specifications

	S-500	S-500L
<b>Rated Voltage</b>	US Model: AC 100-120V, 50/60Hz 7.5A EU Model: AC 220-240V, 50/60Hz 4.0A	
<b>Rated Power</b>	120V 900W 240V 880W	
<b>Fluid Consumption</b>	400 ml/min (100% output)	
<b>Fluid Tank Capacity</b>	20 Liters (5.28 Gallon)	
<b>Compatible Fluid</b>	Antari SL-N Snow & Foam Fluid (New Formula) 、 Antari SL-AN Premium Snow Fluid (New Formula) 、 Antari SL-H Super Dry Snow Fluid 、 Antari SL-C Anti-Freezing Snow Fluid 、 Antari SL-UV UV Snow Fluid	
<b>Ambient Temp. Range</b>	5°C – 40°C (41°F – 104°F)	
<b>Control Methods</b>	Manual 、 Timer 、 DMX512 、 W-DMX (Optional) 、 Wireless (Optional) 、 Cable Remote (Optional)	
<b>Interface</b>	XLR 3-Pin Connector (DMX) 、 XLR 5-Pin Connector (DMX) 、 XLR 4-Pin Connector (Remote) 、 Neutrik powerCON Connector (Power)	
<b>DMX Channels</b>	2 Channels	
<b>Included Accessories</b>	ST-10 10 Meter Extension Hose x 1	ST-10 10 Meter Extension Hose x 2
<b>Optional Accessories</b>	TIMO-W-DMX-PCBR W-DMX Receiver 、 WTR-20 Wireless Remote 、 TIMO-WTR-70 2in1 Wireless Module (Wireless+W-DMX) 、 SC-3 Cable Remote 、 ST-10 10Meter Extension Hose 、 PM-1 Pan Motor	
<b>Dimension</b>	L 592 W 551 H 651 mm (L 23.31 W 21.69 H 25.63 inch)	L 803 W 603 H 651 mm (L 31.61 W 23.74 H 25.63 inch)
<b>Weight</b>	37.2 kg (82.01 lbs.)	46.4 kg (102.29 lbs.)

## 19. Warranty Disclaimer

We guarantee the merchandise manufactured by us to be free from defect in material and workmanship for a period of one year. Our obligation and liability under this warranty shall be restricted to repair or replacement at our factory or local authorized dealer. We assume no liability of the products that are improperly used or used for any purpose other than that for which they are specially designed. This warranty shall not apply to any merchandise which has been repaired, altered or assembled outside our factory in any way so as in our judgment to affect its performance, nor which has been subjected to misuse, negligence, or accident nor to any merchandise operated contrary to our printed instructions. We will not allow or be liable of any loss or any damages of any kind in connection with the use, sale, or repair of any merchandise purchased from us.

## 20. Machine Dimension

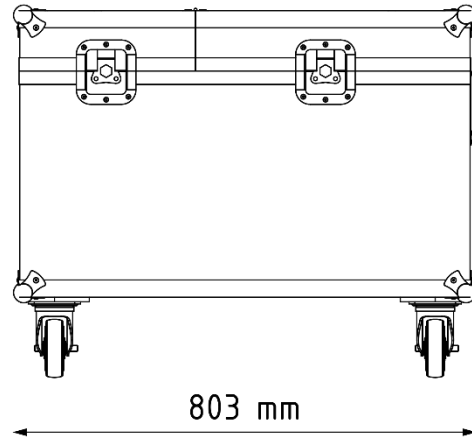
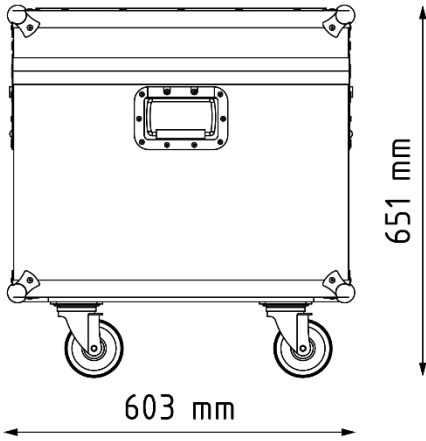
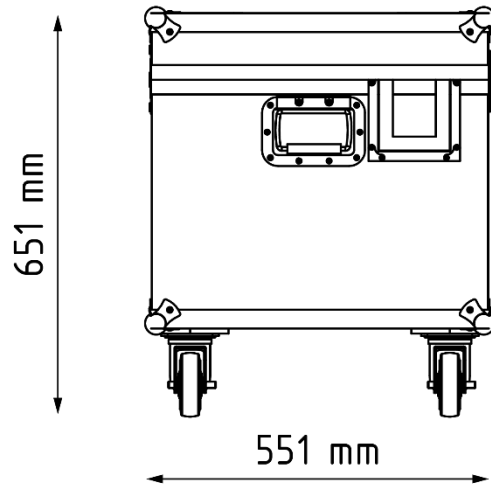
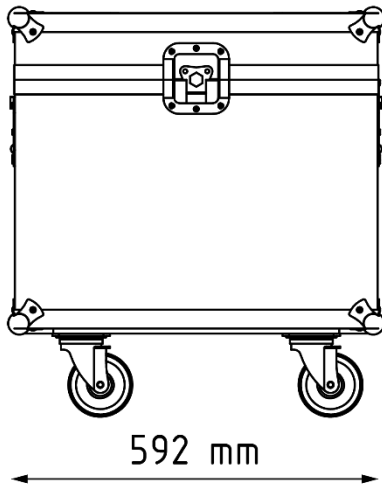

# SILENT SNOW MACHINE



# S-500

## 中文使用說明書

### 1. 前言

在操作本機器之前，請務必仔細詳閱本說明書然後請將本說明書放置在機器使用者可隨時查閱之處存放。此說明書包含如何安全的安裝及操作本機器以及說明所有在機器上的標示。如果您有任何操作上的問題，請立即聯繫當地的 Antari 經銷商尋求協助。

### 2. 安全注意事項

 <b>危險</b>	若不確實避免這些指示，可能導致嚴重人身傷害甚至死亡。
 <b>警告</b>	若不確實遵循這些指示，可能導致嚴重人身傷害甚至死亡。
 <b>注意</b>	若不確實注意這些指示，可能導致人身傷害甚至死亡，嚴重程度視情況而定。

#### 危險

- 請務必使用正確電壓。如果使用錯誤電壓，可能會遭受危險的電擊燒傷或更嚴重的後果。
- 請務必將機器連結到有保護的電路，並確保有正確的接地，以避免觸電的危險。關於接地方式請參考第 23 頁附錄 I。
- 請勿在捆綁電源線的情況下使用，可能會發熱導致火災。
- 操作機器時請勿將機器對著人體、動物或火焰使用。

#### 警告

- 請於堅固、平坦、穩定且通風良好的表面上使用機器。請勿遮蓋機器散熱部份，機器周邊至少應保留 50 公分的空間並確認附近沒有易燃性物質或可揮發性氣體。
- 請勿隨意拆卸、修理或改造機器，這可能會導致機器故障、損壞、觸電危險或造成火災。
- 本機器僅限有行為能力之成人或專業人員操作，不預期提供生理、感知、心智能力、經驗或知識不足者之使用者(包含孩童)使用本機器。
- 請勿在無人看管時讓機器運作，並於外出離去時確實關閉電源。
- 孩童應受監督，以確保孩童不能操作或嬉戲玩本機器。
- 請勿將機器放倒或傾斜使用，可能導致機器動作不正常或損壞。
- 請將液體存放在室內孩童無法取得之處，保持通風及避免陽光直射。如果有觸碰眼睛或誤食機器，請立即尋求醫生的協助。

#### 注意

- 本機器無防水設計，請隨時保持機器乾燥，嚴禁將其潑水、浸水、淋雨或放在潮溼的環境。
- 在插入電源插座前，請確認電源插座無損壞或鬆動。
- 若電源線損壞，必須使用原廠電源線或組件進行更換，否則將導致保固無效。
- 請在使用機器之前，先填裝好雪花水，避免機器幫浦空轉過熱造成損害。機器在搬運前或使用完畢後，請清空油桶。
- 在運輸本機器前，請確認機器的油桶已清空並且包裝完整。(建議使用原廠包裝)
- 本產品僅限室內使用。
- 請勿在電壓不穩定的地區使用本機器。
- 如果機器出現異常聲音或有任何不正常現象時，請立即停止工作，將電源關閉及拔下機器電源線，並請聯繫當地的 Antari 經銷商尋求協助。

- 請勿觸碰機器內部運轉零件。
- 只能使用原廠建議或販售之配件。
- 請確認機器不在使用的狀態下電源已關。如果長時間不使用機器，請拔掉電源線。
- 關閉機器時，將控制開關轉到關閉的位置，然後再將插頭從插座拔除。
- 拔除電源線時，請抓住插頭不是電線。
- 在保養及清潔前，請把電源線從插座拔除。
- 在電線或插座有損毀、機器故障或有掉落或損壞的情形發生時，請勿操作機器。請將機器送回最近的維修站，做檢查、維修及電源或機械的調整。
- 為確保機器的使用壽命，請使用 Antari 原廠製造之雪花水，勿使用其它非 Antari 原廠製造雪花水或添加劑，否則可能會導致故障。

在使用本機之前，請詳細閱讀機器上的警語標示，說明如下：

#### 上蓋印刷

**WARNING! 警告!**

PLEASE USE ANTARI FLUID ONLY. 只能使用 Antari 雪花水

NEVER ADD FLAMMABLE SUBSTANCE. 禁止添加易燃物質

### 3. 包裝內容與檢查

在收到機器後，請立即小心地打開包裝紙箱，檢查所有內容，確認您所購買的機型及配件。如果有任何部件因運輸過程出現損壞或缺少，請立即連絡經銷商，並以原包裝退回檢查。

#### 3.1 包裝內容

S-500	S-500L
1 x S-500 雪花機	1 x S-500L 雪花機
1 x 20 公升油桶	1 x 20 公升油桶
1 x 油管(15 公分)	1 x 油管(15 公分)
1 x Neutrik powerCON 電源線	1 x Neutrik powerCON 電源線
1 x 伸縮軟管 10 米	1 x 伸縮軟管 20 米
1 x 噴頭	1 x 噴頭
1 x 說明書或掃描機身 QR CODE	1 x 說明書或掃描機身 QR CODE

#### 3.2 選配說明

品項	描述
SC-3	有線控制器
WTR-20	無線控制器(W-2 無線發射器/W-2 無線接收器)
TIMO-WTR-70	二合一無線模組(無線+無線 DMX)
TIMO-W-DMX-PCBR	無線 DMX 接收器
ST-10	伸縮軟管 10 米
PM-1	搖頭旋轉台

## 4. 機器訊息

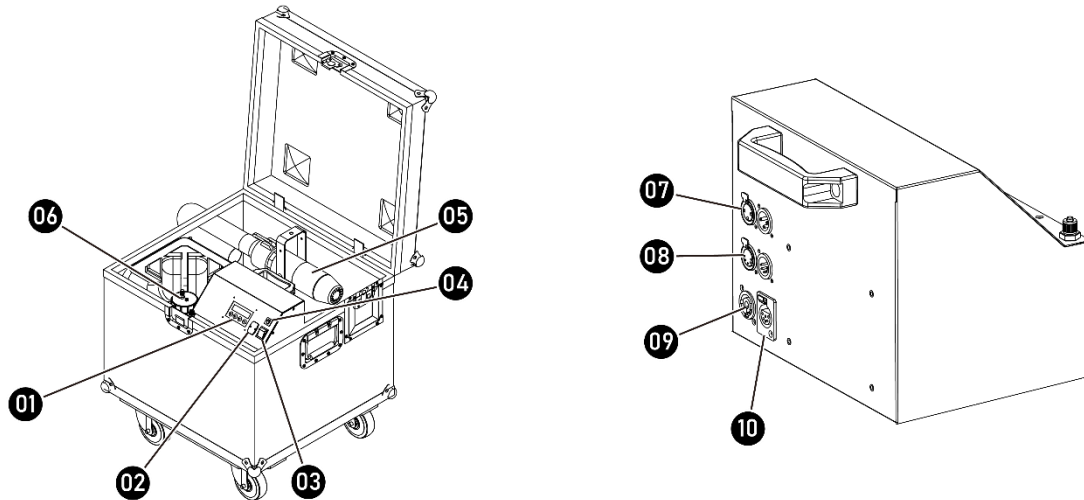

01. 數位控制面板	06. 20 公升油桶
02. 擴充槽	07. XLR 3-Pin 連接頭(DMX)
03. 電源開關	08. XLR 5-Pin 連接頭(DMX)
04. 斷路器	09. Neutrik powerCON 連接頭(主電源)
05. 噴嘴	10. XLR 4-Pin 連接頭(控制器)

## 5. 技術標籤資訊

使用本機器前，請詳閱技術標籤上的訊息

1. 機器型號	5. 斷路器/保險絲
2. 工作電壓	6. 說明書 QR CODE
3. 頻率	7. 機器流水序號
4. 瓦特數	

## 6. 雪花水

	<b>危險</b>	將液體加入機器之前，請務必先拔除電源線。請勿添加易燃液體。如果發現液體流入機器內部，請洽 Antari 原廠或其經銷商尋求協助。
--	-----------	--

- 僅能使用 Antari 原廠製造之雪花水，不可混用或稀釋。
- 本機器是使用專屬的雪花水做測試與校正來取得最佳的效能。
- 如需更換另一種液體，請在使用前，先將油桶中的液體清空，以避免混合。
- 如果使用非原廠製造之雪花水而導致雪花機損壞將不在保固範圍內。



## 7. 設定與手動操作說明



### 警告

機台掉落可能會造成嚴重傷害，請確保本機台安裝牢固且不會掉落。

- 步驟1. 將機器平放在堅固、平坦、穩定且通風良好的表面上，機器周圍至少應保留 50 公分的空間並確認附近沒有易燃性物質或可揮發性氣體；
- 步驟2. 將 ANTARI 原廠雪花水倒入油桶；
- 步驟3. 將機器連接電源，連接之前，確認機器背後技術標籤上所標示要求功率，是否與電源插座相符；
- 步驟4. 啟動機器電源後，當機器已經準備好可進行操作時，螢幕會顯示“Antari S-500 Ready to Snow”；
- 步驟5. 欲開始製造雪花，按一下控制面板上的[TIMER]；停止製造雪花，請按一下控制面板上的[STOP]，這會按照設定的“間隔時間”&“持續時間”來運轉；
- 步驟6. 或欲開始製造雪花，按一下控制面板上的[VOLUME]；停止製造雪花，請按一下控制面板上的[STOP]；
- 步驟7. 需關閉本機時，請確認機器已停止運轉，再將電源開關關閉即可，長時間不使用時請移除電源線。

## 8. 可調式安裝支架

下圖顯示如何調整支架，使用螺絲進行表面安裝或使用夾具安裝在桁架上。

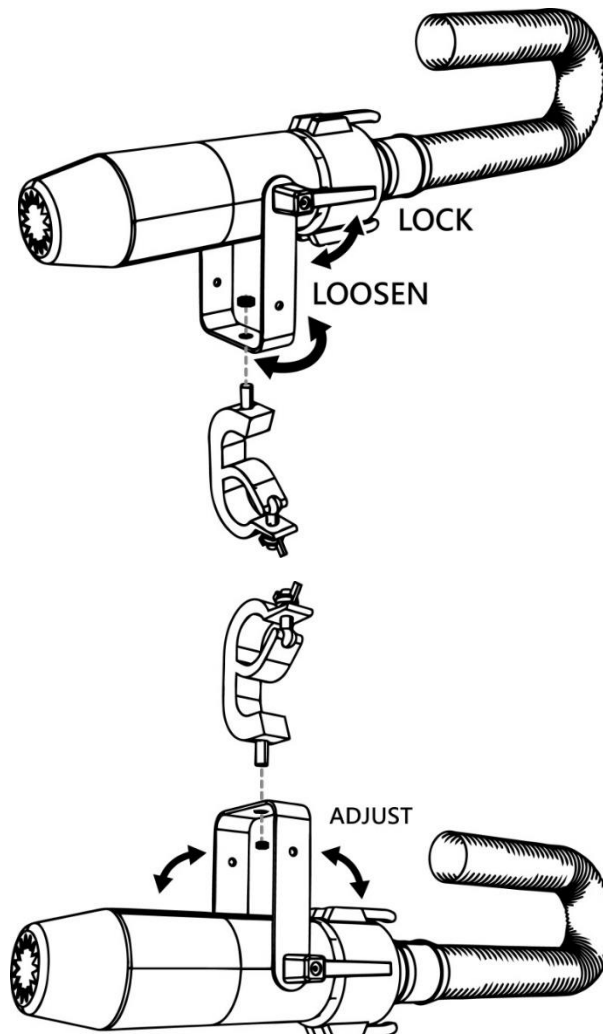

### 注意：

- 使用安裝支架或吊掛夾具來安裝噴頭。
- 確認安裝處、固定接頭以及吊掛索具可以支撐噴頭 10 倍以上的重量。

- 確認周邊沒有任何易燃的材料。
- 安裝噴頭時，請務必使用可以支撐噴頭 10 倍重量以上的安全繩索。
- 請將噴頭安裝在通風良好的地方。
- 在選擇噴頭的安裝地點時，請將噴頭位置及定期維護的方便性納入考量。

## 9. 控制設定

S-500/S-500L 雪花機可以使用下列操作模式，機器每次接受一種訊號。

- 手動控制
- 定時控制
- DMX512
- W-DMX
- 無線控制
- 有線控制

### 9.1 控制面板說明



S-500/S-500L 雪花機可以使用機器上的數位控制面板來操作。

按鈕	操作方式	功能
	按	進入選單畫面及瀏覽
	按	增加數值 / 上
	按	減少數值 / 下
	按	啟動”TIMER”模式
	按	啟動”VOLUME”模式
	按	停止/返回

#### 語言設定

欲更改操作介面的語言設定，在啟動機器之前，按住[MENU]再啟動機器，直到 LCD 螢幕閃兩下。閃了兩下之後，按下[MENU]來選擇語言：English（英文）與中文，再按下[STOP] 來紀錄選擇的語言選項。

### 9.2 選單說明

選單	敘述
Timer Interval xxx Sec	設定間隔時間 15 – 360 秒
Time Duration xxx Sec	設定煙霧輸出時間 5 – 120 秒
Timer Output xxx%	設定輸出量 1 – 100% (定時模式)

選單	敘述
Volume Output xxx%	設定輸出量 1 – 100% (輸出量模式)
Fan Speed xxx%	設定風扇轉速 20 – 100%
DMX512 Add.xxx	設定 DMX / W-DMX 地址 001 - 511
W-DMX Power xx	開啟/關閉 無線 DMX 功能
W-DMX Reset xx	取消與 W-DMX 發射器的連接
Wireless	開啟/關閉 無線功能
Wireless Register Up: Pair Down: Del	配對/取消 配對 無線控制器 (當無線功能關閉時，不會顯示)
Run Last Setting	開啟/關閉 記憶模式(選擇 ON 機器會記錄最後一次設定)

## 10. DMX 說明

### 10.1 DMX 說明

本機可提供一個 XLR 3-PIN / 5-PIN 的 DMX 連接頭選擇。下為 PIN 的接點說明：

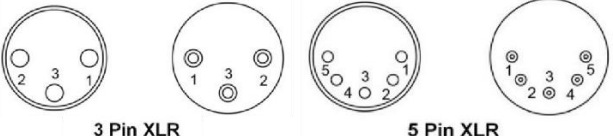

3 Pin XLR                      5 Pin XLR

Pin	功能
1	接地
2	數據-
3	數據+
4	N/A
5	N/A

DMX IN 連接頭上的蓋子是一個保護蓋，操作前，請用手指撥開即可輕鬆地將其取下。

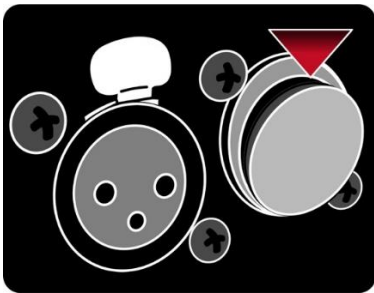

### 10.2 DMX 通道功能設定

通道 1	DMX 數值範圍	功能
雪花輸出	0 – 5	關閉
	6 – 255	輸出 1 – 100%
通道 2	DMX 數值範圍	功能
風扇輸出	0 – 5	風扇 20%
	6 – 255	風扇輸出 21 – 100%

## 11. 無線 DMX 訊號說明

本機的無線 DMX 功能可同時支援 CRMX 以及 W-DMX 協議

### 11.1 連接狀態說明

LCD 螢幕上所顯示的符號	無線 DMX 連結狀態
○	沒有對頻任何無線 DMX 發射器
◎	無線 DMX 發射器已對頻，但沒有 DMX 訊號
◉	無線 DMX 發射器連接遺失 / 正在與發射器連接
●	無線 DMX 發射器已對頻，接收到 DMX 訊號

## 12. SC-3 有線控制器(選配)



SC-3 有線控制器是 S-500/S-500L 雪花機的選購配件，使用方法如下；

按鈕/旋鈕	功能
VOLUME[旋鈕]	調整雪花輸出量
FAN[旋鈕]	調整風扇轉速
POWER[紅色按鈕]	控制器 開/關(可調雪花整輸出量及風扇轉速)
MAX FAN[綠色按鈕]	鎖定風扇轉速最大，只可以調整雪花輸出量
PRIMING[黃色按鈕]	雪花輸出量及風扇轉速皆為最大，無法調整

注意：

\*\*務必按下紅色按鈕開啟控制器電源才能使用。

\*\* PRIMING[黃色按鈕]當新機器第一次使用、換一個新的油桶或是添加雪花水後，幫浦可能因為油管中有空氣而無法順暢運作，此時可以使用此功能，將風扇與幫浦的輸出量設定到最大，藉此將油管中的空氣排出。

\*\*如果有任何問題，請聯繫當地的 Antari 經銷商尋求協助。

## 13. WTR-20 無線控制器(選配)

WTR-20 無線控制器組包含一個 W-2 無線發射器及 W-2 無線接收器，此為 S-500/S-500L 雪花機的選購配件。若您採購的版本已含無線功能，可直接使用。若是後續採購 WTR-20 無線控制器，請按照下方說明進行安裝與配對。如果遇到任何困難與問題，請與當地的 Antari 經銷商尋求協助。

### 13.1 W-2 無線發射器/接收器說明

- 發射器：使用 27A 12V 電池
- 收發距離：有效距離為 50 公尺，實際收訊狀況根據現場環境因素而有所不同。
- 如果發現收發距離明顯縮短時，請更換電池。
- W-2 無線發射器配有 4 個按鈕，控制功能為：

按鈕	功能
[A] 鍵	開始噴雪
[B] 鍵	停止噴雪
[C] 鍵	增加雪花輸出量
[D] 鍵	減少雪花輸出量



W-2 無線發射器

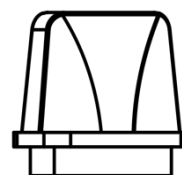

W-2 無線接收器

## 13.2 W-2 接收器安裝說明

如果是後續採購 WTR-20 無線控制器，請按照下方說明進行安裝與配對。如果遇到任何困難與問題，請與當地的 Antari 經銷商尋求協助。



圖 1



圖 2

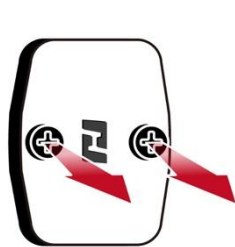

圖 3

1. 請看圖一，取下蓋子;
2. 請看圖二，取下後，你會看到一條白色的線，請拉出來接在 W-2 無線接收器上;
3. 請看圖三，將接收器鎖回去原本的地方，然後按照 13.3 的步驟開始配對。

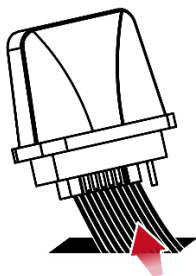
## 13.3 配對 & 取消配對

每個接收器可以配對最多五個發射器，請參考下列步驟進行配對與取消配對。

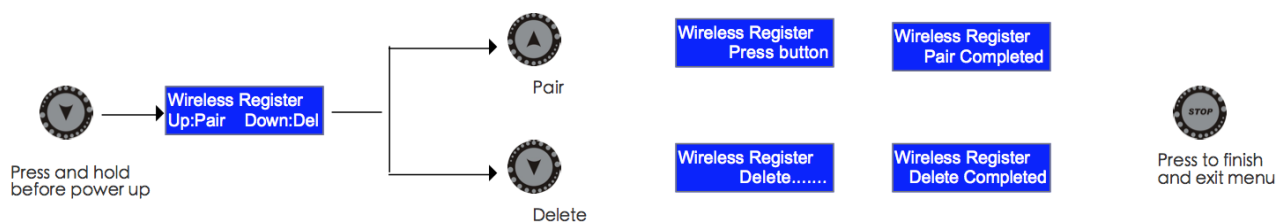

## 14. TIMO-WTR-70 二合一無線模組(選配)

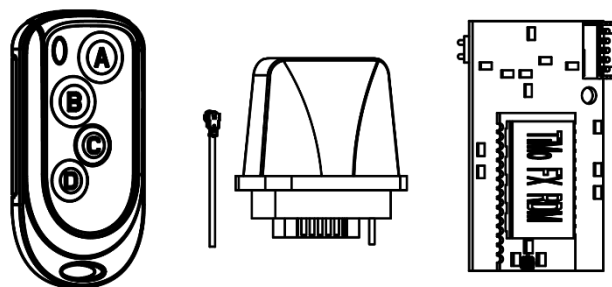

TIMO-WTR-70 是二合一無線模組(無線+無線 DMX)，此為 S-500/S-500L 雪花機的選購配件。若您採購的機器已包含此配件，可直接使用。若是後續採購，請另外參照安裝說明。如果遇到任何困難與問題，請與當地的 Antari 經銷商尋求協助。

## 15. TIMO-W-DMX-PCBR 無線 DMX 接收器(選配)

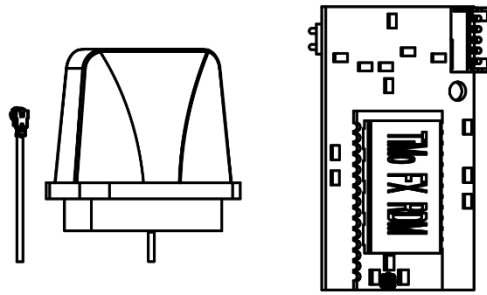

TIMO-W-DMX-PCBR 是無線 DMX 接收器，此為 S-500/S-500L 雪花機的選購配件。若您採購的機器已包含此配件，可直接使用。若是後續採購，請另外參照安裝說明。如果遇到任何困難與問題，請與當地的 Antari 經銷商尋求協助。

## 16. ST-10 延長管(選配)

伸縮軟管最長為 20 公尺，下圖顯示如果連接延長管連接方式。

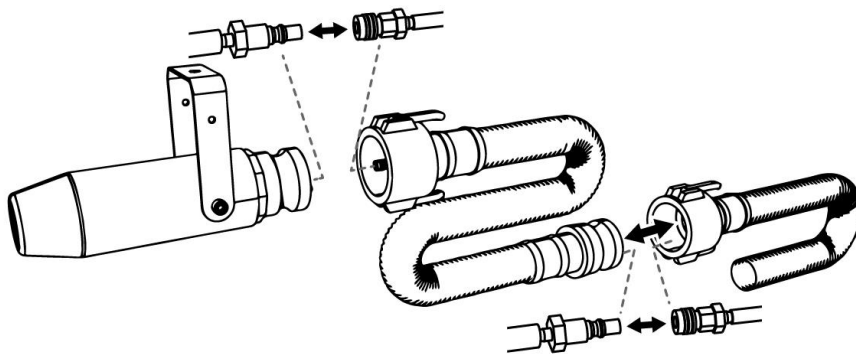

## 17. 維護和保養



**危險**

維修保養之前，請務必拔除電源線！

- 隨時保持機器清潔及乾燥。
- 可以使用空氣壓縮機、吸塵器或軟刷除去機器上的灰塵。
- 機殼可使用濕布擦拭。
- 儲藏前或使用完畢後，請在油桶內倒入清水，讓機器運行 1-2 分鐘，清潔機器內的殘餘雪花水，延長機器使用的壽命。
- 建議每月至少讓機器運轉一次，以保持機器處於最佳的性能和輸出條件。
- 機器上過多的灰塵、液體殘餘累積的髒污會降低機器工作性能，導至散熱不良。



## 17.1 重置電流斷路器

請根據下列步驟，重置電流斷路器。

**步驟1.** 關閉機器電源

**步驟2.** 將電流斷路器復歸

**步驟3.** 重新開啟機器測試

\*\*如果遇到任何困難與問題，請與當地的 Antari 經銷商尋求協助。

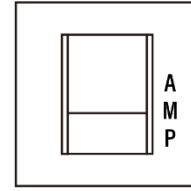

### 電流斷路器規格

120V = 10A 250V

240V = 5A 250V

## 18. 技術規格

	S-500	S-500L
電壓	美規：AC 100 - 120V, 50 / 60 Hz 7.5A 歐規：AC 220 - 240V, 50 / 60 Hz 4.0A	
額定功率	120V 900 瓦 240V 890 瓦	
耗油量	400 毫升/分鐘 (100%輸出)	
油桶容量	20 公升 (5.28 加侖)	
適用雪花水	Antari SL-N 新配方雪花水、Antari SL-AN 高揮發性雪花水、Antari SL-H 高發泡雪花水、Antari SL-C 抗凍雪花水、Antari SL-UV UV 雪花水	
適用環境溫度	5°C – 40°C (41°F – 104°F)	
控制方式	手動控制、定時控制、DMX512、無線 DMX(選配)、無線控制(選配)、有線控制(選配)	
連接座	XLR 3-Pin 連接頭(DMX)、XLR 5-Pin 連接頭(DMX)、XLR 4-Pin 連接頭(控制器)、Neutrik powerCON 連接頭(主電源)	
DMX 512 通道	2 個頻道	
隨附配件	ST-10 10M 延長管 x 1	ST-10 10M 延長管 x 2
選購配件	TIMO-W-DMX-PCBR 無線 DMX 接收器、WTR-20 無線控制器、TIMO-WTR-70 二合一無線模組(無線+無線 DMX)、SC-3 有線控制器、ST-10 10 米延長管、PM-1 搖頭旋轉台	
尺寸	長 592 寬 551 高 651 公釐 (長 23.31 寬 21.69 高 25.63 英寸)	長 803 寬 603 高 651 公釐 (長 31.61 寬 23.74 高 25.63 英寸)
重量	37.2 公斤 (82.01 磅)	46.4 公斤 (102.29 磅)

## 19. 保固聲明

本公司保證我們的商品在一年內沒有材料和製作缺陷。我們在本保證下的義務和責任僅限於在原廠或當地授權經銷商進行的維修或更換。我們對不當使用或用於非專門設計目的以外之用途不承擔任何責任。本保固不適用於以任何方式在原廠或當地授權經銷商外修理、改動或組裝的任何商品，以便我們判斷影響其性能，沒有受到誤用、疏忽或事故的影響，也沒有違反我們的任何商品操作印刷說明。本公司對於從我們這邊購買的商品不會允許也不對於使用、銷售或修理任何產品有關的任何類型的任何損失或損害承擔責任。

## 20. 機器尺寸圖

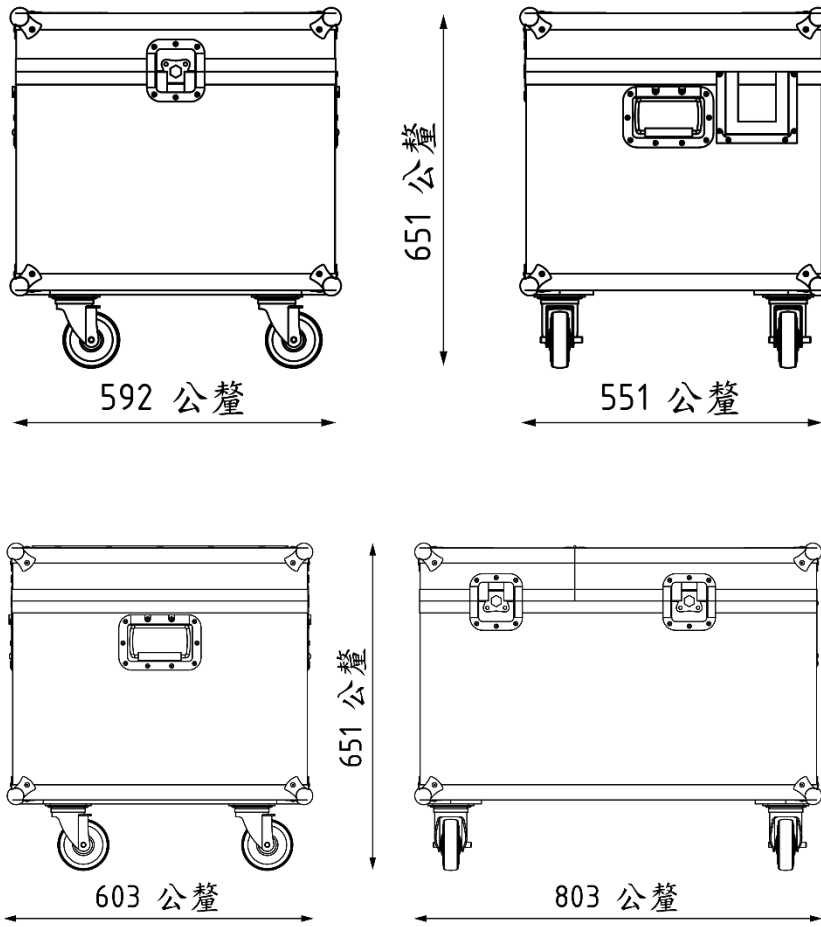



## Appendix I – Grounding Instruction

This appliance must be grounded. In the event of malfunction or breakdown, grounding provides a path of least resistance for electric current to reduce the risk of electric shock. This appliance is equipped with a cord having an equipment-grounding conductor and a grounding plug. The plug must be plugged into an appropriate outlet that is properly installed and grounded in accordance with all local codes and ordinances.

**DANGER** – Improper connection of the equipment-grounding conductor can result in a risk of electric shock. The conductor with insulation having an outer surface that is green with or without yellow stripes is the equipment-grounding conductor. If repair or replacement of the cord or plug is necessary, do not connect the equipment-grounding conductor to a live terminal. Check with a qualified electrician or serviceman if the grounding instructions are not completely understood, or if in doubt as to whether the appliance is properly grounded. Do not modify the plug provided with the appliance – if it will not fit the outlet, have a proper outlet installed by a qualified electrician.

This appliance is for use on a nominal 120V circuit, and has a grounding plug that looks like the plug illustrated in sketch A in Figure. A temporary adaptor, which looks like the adaptor illustrated in sketches B and C, may be used to connect this plug to a 2-pole receptacle as shown in sketch B if a properly grounded outlet is not available. The temporary adaptor should be used only until a properly grounded outlet can be installed by a qualified electrician. The green colored rigid ear, lug, and the like, extending from the adaptor must be connected to a permanent ground such as a properly grounded outlet box cover. Whenever the adaptor is used, it must be held in place by the metal screw.

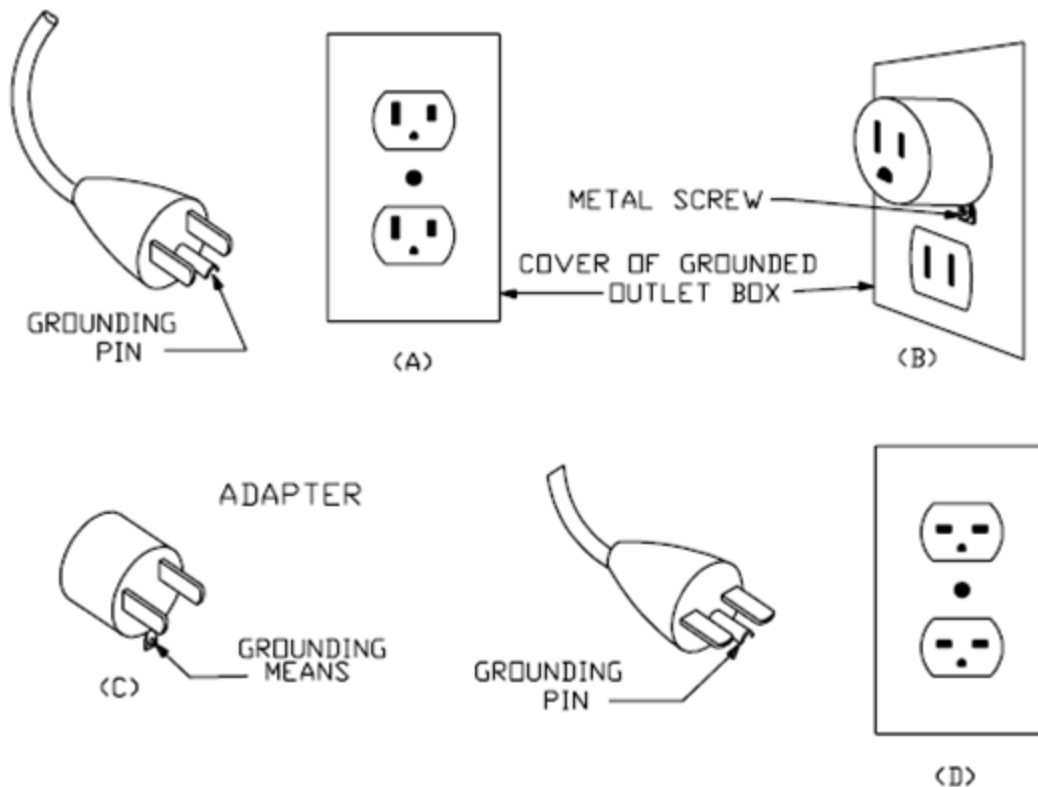







C08S50007